



Power Transformers

Anoop Kumar Kanaujia

Assistant Professor (Sugar Engineering)



Overview

- Introduction
- Need of Transformers
- Elements of Transformer
- Type of Transformers
- Losses in Transformers
- Transformers Routine Tests
- Conditions for Parallel Operation of Transformers
- Auto Transformers
- Instrument Transformers
- Power Transformer vs Induction Motor
- Maintenance of Transformers



Introduction

Principle of Operation

- It is an electro-magnetic device & its operation is based on the concept of mutual induction.
- The primary winding is fed by sinusoidal ac voltage. The current in primary winding sets up an alternating flux in the core.
- The secondary winding is also linked by this flux and emf induced in two windings.
- The emf induced in the secondary winding causes a current through the load.
- Thus energy is transferred from primary circuit to secondary circuit through medium of magnetic field.

EMF Equation of Transformer

- RMS value of induced emf = $4.44 fN\phi_m$

Where f = Frequency

N = No. of turns

ϕ_m = Max. value of flux

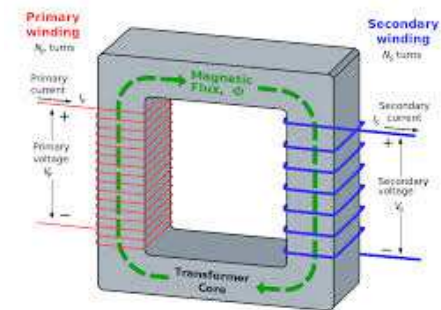
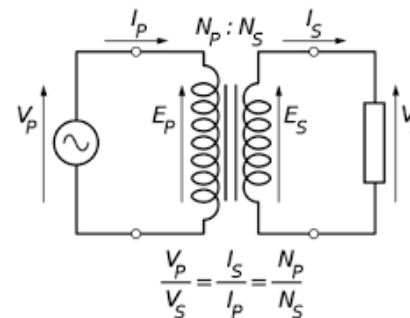



Need of Transformers ?

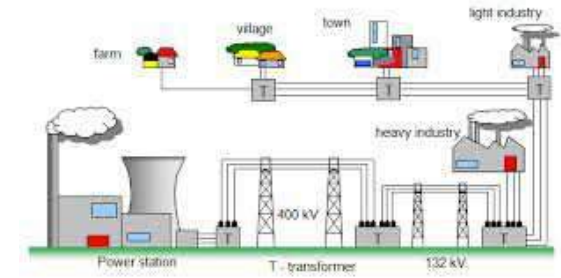

Need of Transformers

- Main advantage of ac power transmission / distribution is that it can be increased or decreased very easily.
- In general electrical power is generated at 11 kV / 33 kV level (as determined by generator design limitations such as insulation, cooling etc.).
- To convert it into high voltage (≥ 132 kV), extra high voltage (≥ 400 kV) and ultra high voltage (≥ 765 kV) which results in lesser cost of transmission line, reduced power loss i.e. improve efficiency & improve voltage regulation, there will be need of the transformers.
- At distribution points transformers are used to decrease the voltage to safe level of 440 / 230 V for use in houses, offices etc.
- Thus conversion of voltage is possible only due to transformers. Without the transformers it would not be possible to use electrical energy in many of ways it is used now-a-days.



Elements of Transformer

1 . Magnetic Circuit

- Iron core – Alloy steels
- Consist of laminated sheets each about 0.35 mm thick, to reduce eddy current losses.

2. Electric Circuit

- Winding, Insulation, Bushings & Tapping

3. Tank

- Cooling Devices, Conservator & Breather

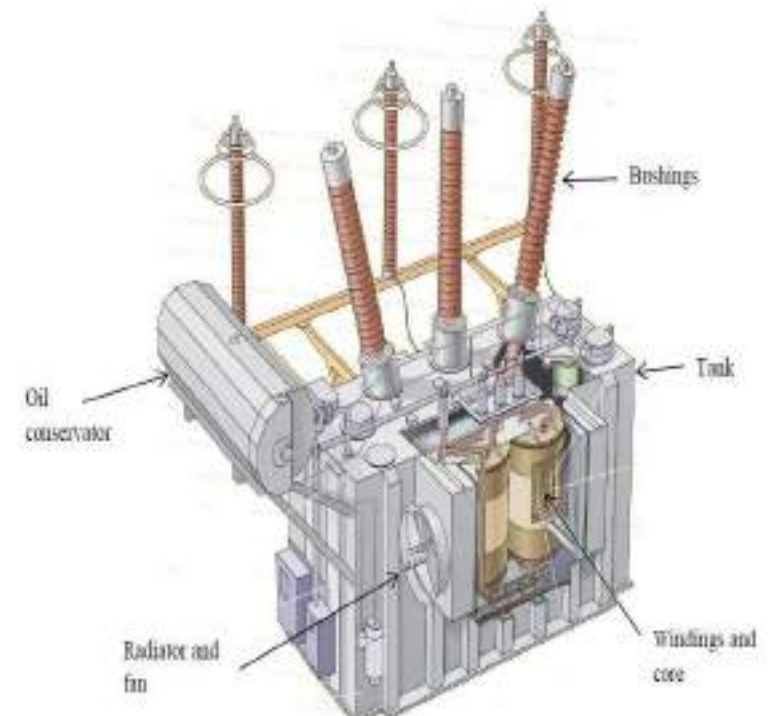



Contd.. Elements of Transformer

Winding

- Concentric winding – L.V. winding is placed nearer to core.
- Sandwiched winding – H.V. winding is placed nearer to core.

Insulation

- Varnish or paper insulation

Bushings

- Outdoor terminal of transformer
- Porcelain or oil filled bushings

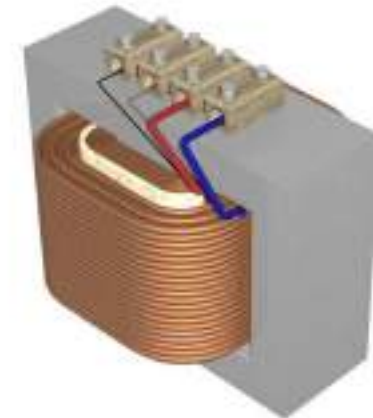



Contd.. Elements of Transformer

Tapping

- To vary terminal end voltage.
- Typical installation have 4 to 20 position taps, with spacing 2.5% of rated voltage.
- Provided at H.V. side
- Off-load tap changer
- On-load tap changer

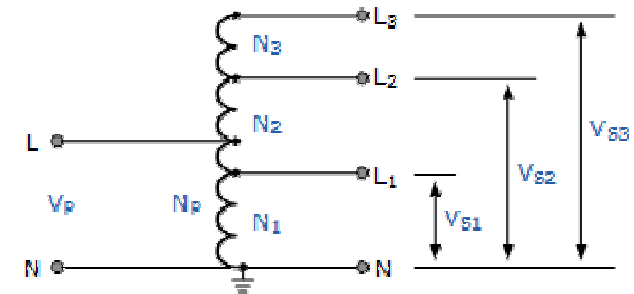

Cooling

- Transformer oil
- ONAN (Radiators) / ONAF (Radiators+Fans)

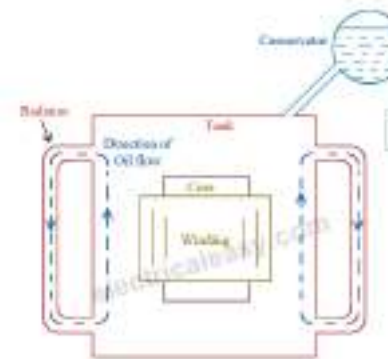

Oil Natural Air Natural (ONAN) - Cooling of Transformer

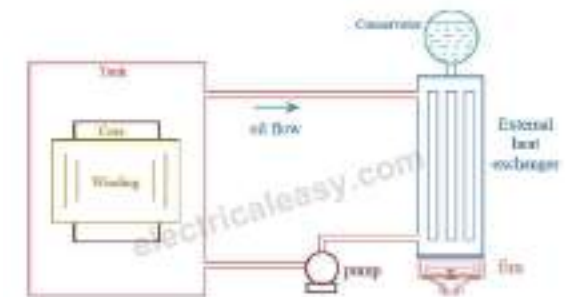

Oil Forced Air Forced (OFAF) - Cooling of Transformer



Contd.. Elements of Transformer

Conservator

- Cylindrical metal drum supported on transformer
- Expansion & contraction of oil takes place with change in temperature



Breather

- Extract moisture from air
- Contains silica gel or calcium chloride

Transformer Noise (Hum)

- Magnetostriction i.e. very small extension of steel sheets when magnetized.





Type of Transformers

1. Core Type

- High voltage transformers
- Concentric winding – L.V. winding is placed nearer to core.

2. Shell Type

- Low voltage transformers
- Sandwiched winding – H.V. winding is placed nearer to core.

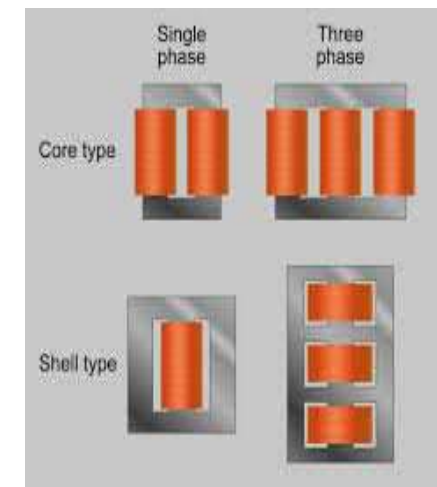



Ideal Transformer

- **Features**

1. No iron loss
2. Winding resistance is zero
3. No magnetic leakage flux
4. Permeability of magnetic circuit is infinite

Transformer invented by Gaulard & Gibbs of France in 1886

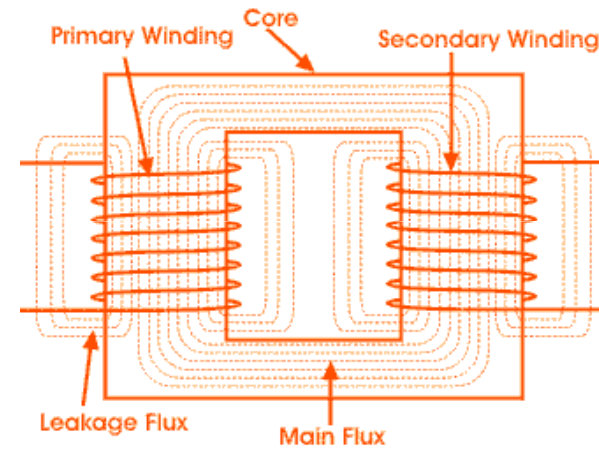



Voltage Regulation

Voltage Regulation of Transformer

- Voltage regulation is the ability of system to provide near constant voltage over wide range of load conditions.

$$VR = (V_{\text{no-load}} - V_{\text{full load}}) / V_{\text{full-load}}$$

- **P.F. Lagging** – Voltage regulation is positive
- **P.F. Unity** – Voltage regulation is positive
- **P.F. Leading** – Voltage regulation is negative
- An ideal transformer has 0% voltage regulation.

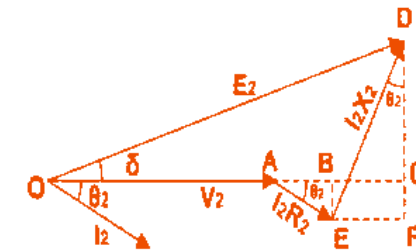

Voltage Regulation at Lagging Power Factor

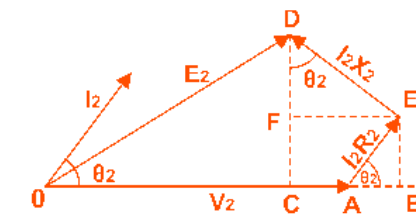

Voltage Regulation at Leading Power Factor



Losses in Transformer

1. Iron or Core Losses

- Constant or No-load losses
- Iron losses = Hysteresis losses + Eddy Current losses

2. Copper Losses

- Load losses
- Copper losses = $I_1^2 R_1 + I_2^2 R_2$
- ✓ Efficiency of Transformer = Power output / Power input
- ✓ Efficiency is maximum when copper losses are equal to core losses.

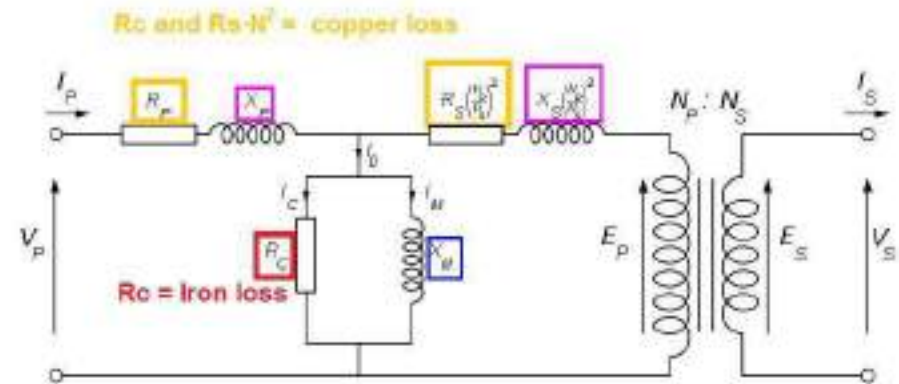



Transformer Routine Tests

Transformer Testing

- **Open Circuit Test (No-load Test)**
 - ✓ Performed at rated voltage, H.V. side kept open circuited, to find out core losses
- **Short Circuit Test (Full-load Test)**
 - ✓ Performed at rated current, L.V. side kept short circuited, to find out copper losses

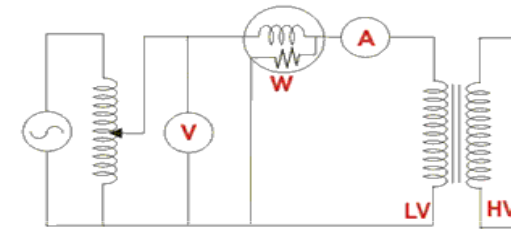

Open Circuit Test on Transformer

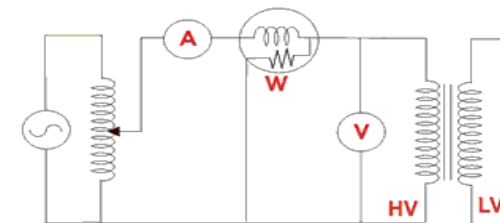

Short Circuit Test on Transformer



Contd.. Transformer Routine Tests

Transformer Testing

- **IR Value of transformer**
 - ✓ Primary & secondary winding in MΩ
- **Ratio Test**
 - ✓ $N_1 / N_2 = E_1 / E_2$

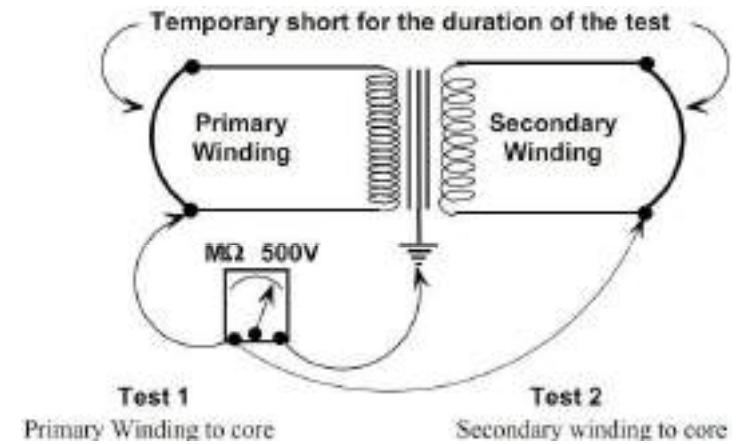



Contd.. Transformer Routine Tests

Transformer Testing

- **BDV Value of Transformer Oil**
 - ✓ Oil BDV > 65 kV
- **Polarity Test**
 - ✓ If $V > V_p$ - Additive Polarity
 - ✓ If $V < V_p$ - Subtractive Polarity

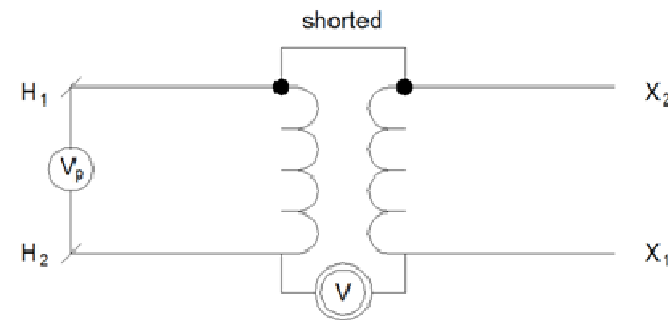



Conditions for Parallel Operation of Transformers

Transformer Parallel Operation Conditions

1. **Same Polarity** – Otherwise dead short circuit may take place
2. **Same Voltage Ratio** – Otherwise circulating currents will flow
3. **Same pu Impedance & Phase Angle** – For proper load sharing of transformers
4. **Same Phase Sequence** – Otherwise dead circuit may occur

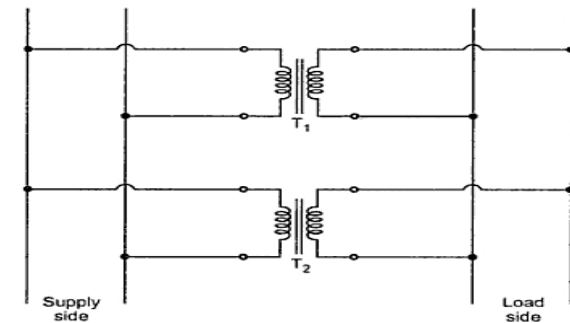



Auto Transformer

Single Winding Transformer

- **Advantage**
 - ✓ Smaller size
 - ✓ Lower cost
 - ✓ Greater efficiency
 - ✓ Better voltage regulation
- **Application**
 - ✓ Continuously variable ac voltage
 - ✓ Starting of ac machines
 - ✓ Boosting voltage
 - ✓ Interconnection of power system of different voltage levels e.g. 132 kV & 220 kV

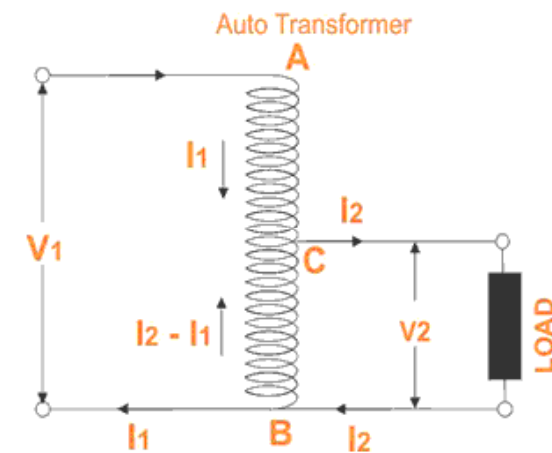



Instrument Transformers

Potential Transformer

- ✓ Step-down transformer
- ✓ For measuring of high voltage
- ✓ Usually secondary is designed for 110 V

Current Transformer

- ✓ Step-up transformer
- ✓ For measuring of high current
- ✓ Usually secondary is designed for 1 A / 5 A
- ✓ Secondary of CT never kept open circuited

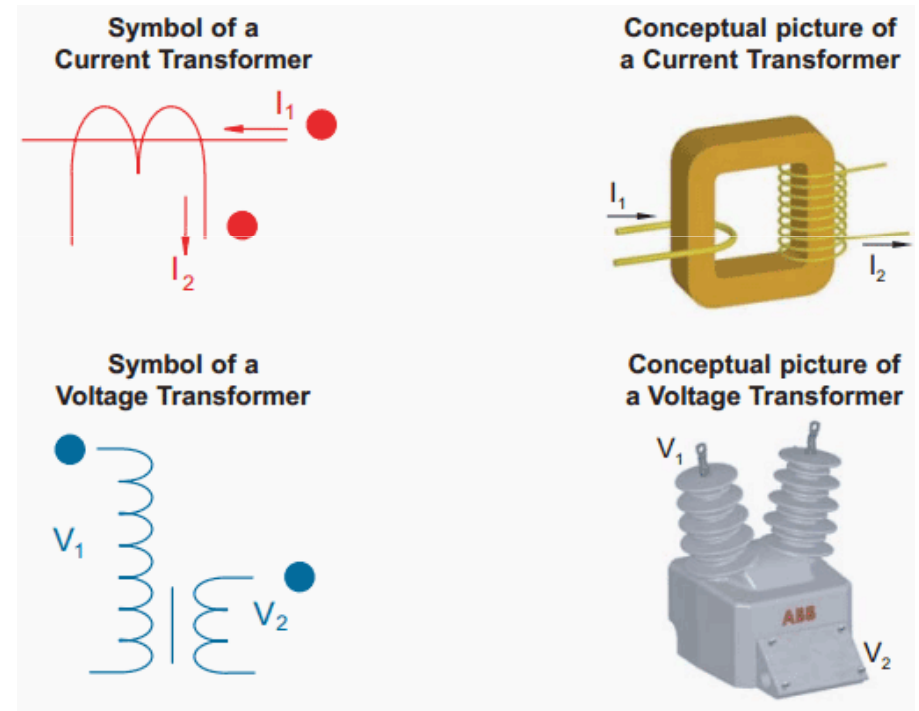



Power Transformer vs Induction Motor

Power Transformer vs Induction Motor

- Transformer is static device whereas an induction motor is rotating device. Therefore air gap exists in an induction motor i.e. magnetizing current is pretty high.
- Because of air gap, leakage flux in an induction motor is higher than transformer.
- Losses are higher and efficiency is lower in an induction motor than in transformer.
- Transformer winding consists of concentrated coils whereas in induction motor winding is distributed in slots.



Transformer Maintenance Schedule

S.No.	Particulars	Frequency
1	Observation of oil & winding temperatures and its recording.	Hourly
2	Visual check for overheating if any at terminal connections (Red hots) and observation for any unusual internal noises.	Each Shift
3	Checking the Colour of silicagel in the breather. If silicagel Colour changes from blue to pink by 50% the silicagel is to be reconditioned or replaced.	Daily
4	Observation of oil levels in (a) main conservator tank (b) OLTC conservator (c) bushings and examining for oil leaks if any from the transformer	Daily
5	Checking for noise, vibration or any abnormality in transformer.	Daily
6	Cleaning of bushings, inspect for any cracks or chippings of the porcelain and checking of tightness of clamps and jumpers	Monthly
7	Measurement of IR values of transformer with 5 KV megger for 132KV rating. Recording of the values specifying the temperature which measurements are taken.	Monthly
8	Cleaning of Silicagel breather	Monthly
9	Checking of temperature alarms by shorting contacts by operating the knob.	Monthly
10	Noting the oil level in the inspection glass of Bucholtz relay and arresting of oil leakages if any.	Monthly



Contd.. Transformer Maintenance Schedule

S.No.	Particulars	Frequency
11	Testing of main tank oil for BDV & moisture content	Quarterly
12	Testing OLTC oil for BDV & moisture content	Quarterly
13	Testing of Bucholtz surge relays & low oil level trips for correct operation	Quarterly
14	Checking of all connections on the transformer for tightness such as bushings, tank earth connection	Quarterly
15	Lubricating / Greasing all moving parts of OLTC mechanism	Quarterly or as given in the manufacturers manual
16	Calibration of oil & winding temperature indicators	Once in a year
17	Turns ratio test at all taps	Once in a year
18	Overhaul of tap changer and mechanism	Once in a year
19	Inspection of OLTC mechanism and contacts its diverter switch	Once in a year or interval of 2000 operations whichever is earlier.
20	Replacement of oil in OLTC	Once in a year or interval of 2000 operations whichever is earlier.
21	Filtration of oil / replacement of oil.	Whenever the IR values of transformer are below permissible limits and oil test results require filtration / replacement of oil



Thank You

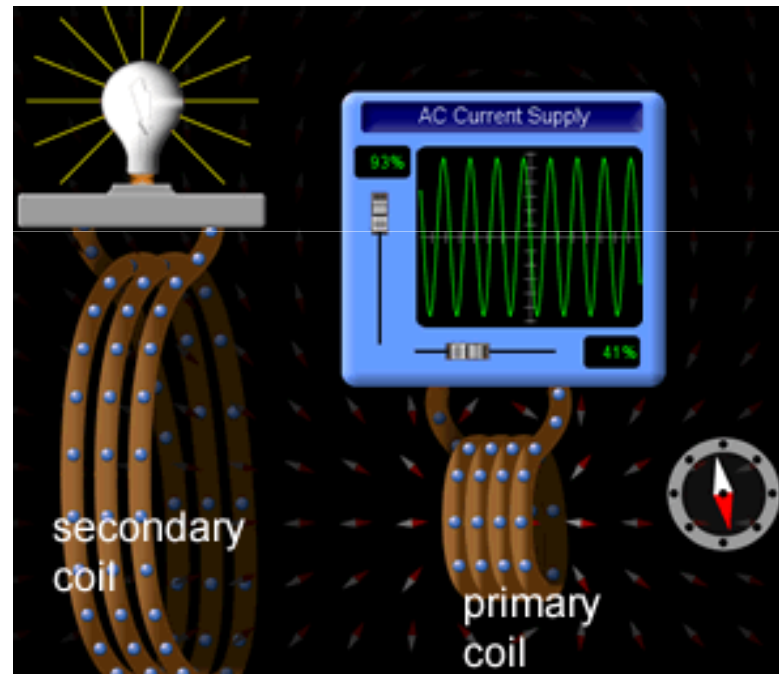

Transformer
Video