



ELEMENTS OF CRYSTALLIZER TREATMENT, CENTRIFUGATION & SUGAR HANDLING



by

Narendra Mohan
Director

National Sugar Institute, Kanpur, U.P., India
Email : nsikanpur@nic.in, director.nsi@gov.in



CRYSTALLIZERS & CRYSTALLIZER TREATMENT

- CRYSTALLIZERS IN GENERAL ARE USED AS HOLDING TANKS FOR THE HIGH GRADE MASSECUITE (i.e. A-massecuite & Refinery massecuites), BUT FOR LOW GRADE MASSECUITES (i.e. B & C – massecuites) THEY PERFORM THE DUAL DUTIES OF HOLDING TANKS AS WELL AS CARRYING OUT THE CRYSTALLIZATION FURTHER BY PUSHING THE SUPERSATURATION HIGHER.
- THE CHOICE OF CRYSTALLIZERS AND DETERMINATION OF THEIR CAPACITY IS DEPENDENT UPON THE TYPE OF MASSECUITE. A-MASSECUITE IS HOT CURED, B- MASSECUITE IS COOLED TO A TEMPERATURE AROUND 52-54⁰C, C- MASSECUITE IS COOLED TO 40-42⁰C AND THEN RE-HEATED IN TRANSIENT HEATERS TO 50-52⁰C. REFINERY MASSECUITES ARE ALSO CURED HOT.



AS FAR AS CAPACITY DETERMINATION IS CONCERNED, IT IS BASED ON FOLLOWING THREE PRINCIPLE FACTORS:

- **QUANTITY OF MASSECUITE TO BE DROPPED. THIS, IN TURN, IS DEPENDENT UPON THE PAN CAPACITY AND IS GENERALLY KEPT APPROX.10% HIGHER THAN THE PAN CAPACITY.**
- **TIME REQUIRED FOR COOLING THE MASSECUITE TO THE DESIRED TEMPERATURE.**
- **TIME TAKEN IN EMPTYING THE CRYSTALLIZER.**



BATCH TYPE CRYSTALLIZERS

TWO TYPES OF CRYSTALLIZERS ARE USED IN SUGAR INDUSTRY:

- BATCH TYPE
- CONTINUOUS TYPE

BATCH TYPE: They may be air or water cooled:

- **AIR COOLED** : THESE CRYSTALLIZERS ARE USED FOR HIGH GRADE MASSECUITES ONLY. THEY ARE “U SHAPED” HORIZONTAL VESSELS MADE OF M.S. PLATES AND FITTED WITH SLOW MOVING STIRRERS SO AS TO KEEP THE MASSECUIE IN AGITATION.

WATER COOLED : THESE CRYSTALLIZERS ARE USED FOR LOW GRADE MASSECUITES AND HAVE EITHER FIXED OR ROTATING COOLING ELEMENTS. THE COOLING ELEMENTS MAY BE IN THE FORM OF COIL OR DISC. THE COOLING SURFACE TO VOLUME RATIO MAY BE KEPT AS 1.5-2.5 M²/M³.



HORIZONTAL AIR/WATER COOLED CRYSTALLIZERS





CONTINUOUS CRYSTALLIZERS

- GROUP OF HORIZONTAL BATCH CRYSTALLIZERS JOINED TO FORM A CONTINUOUS SYSTEM.
- VERTICAL CRYSTALLIZERS.
- GROUPING OF HORIZONTAL BATCH TYPE CRYSTALLIZERS:

GENERALLY 3-7 BATCH TYPE HORIZONTAL CRYSTALLIZERS ARE GROUPED TO FORM A CONTINUOUS SYSTEM. THE CRYSTALLIZERS ARE INTERCONNECTED IN SUCH A MANNER THAT INLET AND OUTLET OF EACH CRYSTALLIZER ARE ON OPPOSITE END. SUITABLE BAFFLE PLATES ARE PROVIDED TO AVOID ANY DEAD POCKETS AND SHORT -CIRCUITING OF THE MASSECUTE. THEY ARE PLACED IN A CASCADING MANNER TO FACILITATE PROPER FLOW.

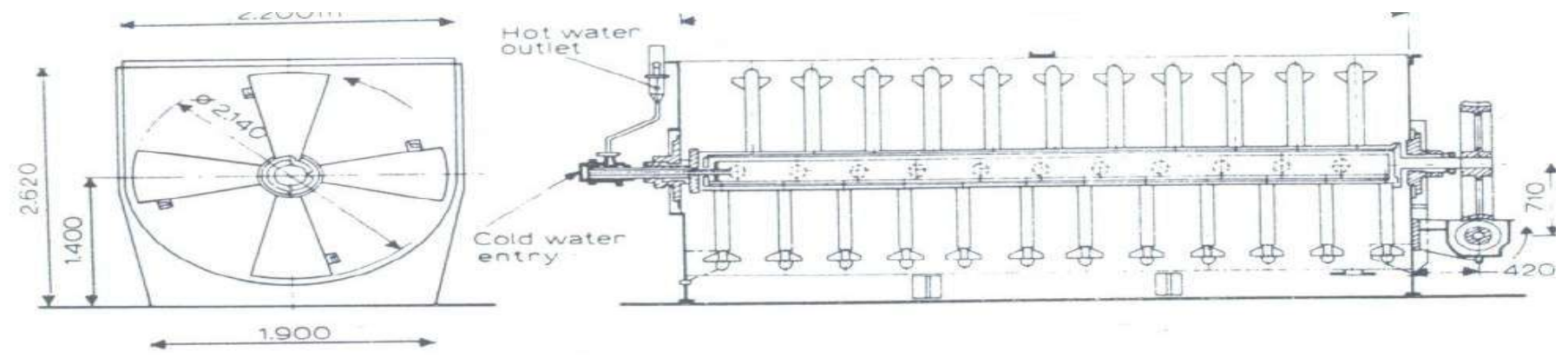

Crystalliser with "flag" stirrers (Fives Cail - Babcock).

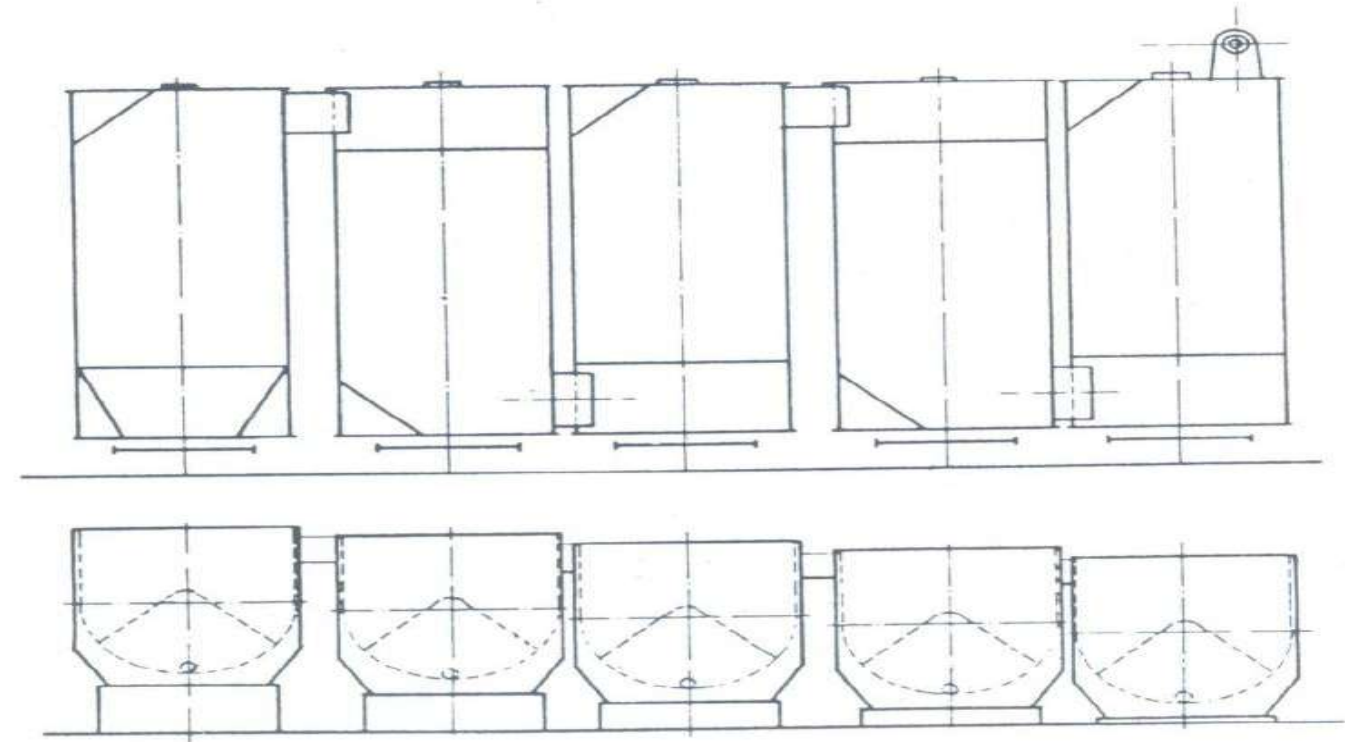

Arrangement of crystallisers in series.



VERTICAL CONTINUOUS CRYSTALLIZERS

THESE MAY BE MONO OR TWIN VERTICAL DEPENDING UPON THE NO. OF VESSELS USED. THE VESSELS WHICH ARE 6-9 METER IN HEIGHT DO HAVE TWO SETS OF FIXED COILS FOR CIRCULATION OF COLD AND HOT WATER AND A STIRRER RUNNING THROUGHOUT THE VERTICAL AXIS CONSISTING OF THE PADDLES FITTED TO THE CENTRAL SHAFT.

THESE CRYSTALLIZERS, WHICH ARE USED FOR LOW GRADE MASSECUITES ONLY, OFFER FOLLOWING ADVANTAGES OVER THE BATCH TYPE CRYSTALLIZERS :

- OCCUPY LESSER SPACE.
- SUITABLE FOR OUTSIDE INSTALLATIONS.
- PLUG- FLOW SYSTEM.
- LOWER POWER REQUIREMENT (BY AROUND 30-50%).
- LESSER COST OF INSTALLATION.

VIEW OF VERTICAL CRYSTALLIZER

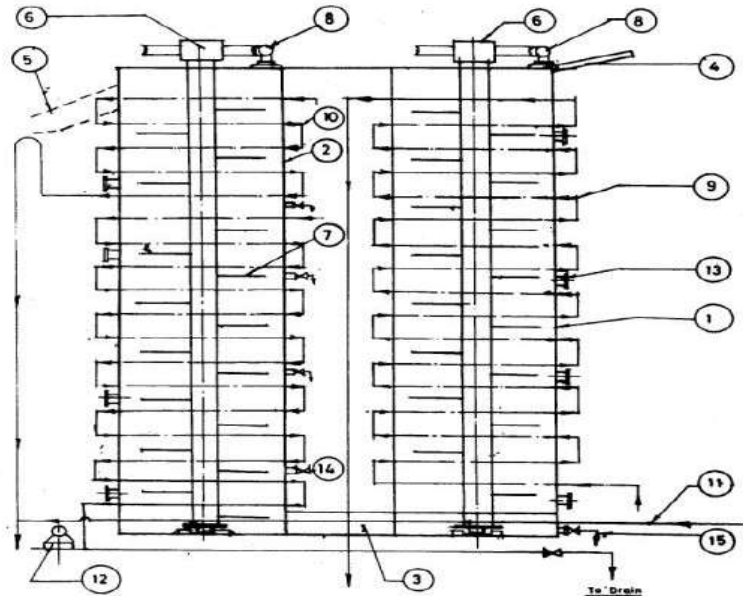

S.NO.	DESCRIPTION	S.NO.	DESCRIPTION
1.	MASSECUITE INLET SHELL	8.	STIRRER DRIVER
2.	MASSECUITE OUTLET SHELL	9.	COLD WATER COILS
3.	SHELL 1 & 2 INTERCONNECTING PIPE	10.	HOT WATER COILS
4.	MASSECUITE INLET PIPE	11.	LIQUIDATION PUMP
5.	MASSECUITE OUTLET GUTTER	12.	MAN HOLES
6.	STIRRER SHAFT	13.	SAMPLING COCKS
7.	STIRRER ARMS	14.	DRAIN VALVES

Twin Continuous Vertical Crystallizer





CENTRIFUGATION

During manufacture of raw or plantation white sugar, the syrup is generally subjected to 3 stage boiling, to prepare A,B & C massecuite. The massecuites are centrifuged to separate the grains and mother liquor. High grade i.e. A massecuite is cured in Vertical Batch, Fully Automatic Recycling or Semi Automatic machines with application of superheated water wash or hot water wash and steaming.



For curing of B and C massecuites, continuous type of centrifugals are generally used with application of some water or dilutants i.e. mixture of molasses and water in the feeding cup to improve mobility or fluidity of massecuites. C massecuites are double cured by making magma of C single cured sugar in water or C- Light molasses. C double cured sugar is melted and used to build A massecuite. B single cured sugar is either melted or used as seed/footing for boiling A massecuite. Generally, B and C double cured sugars are melted and melt is used for A massecuite boiling. Controlled application of wash water and/or steam and running of centrifugals at full load is important to control purities of molasses, maintain quality of sugar and derive optimum capacity utilization.



BATCH CENTRIFUGALS

Machine with 2 types of baskets i.e. flat bottom mechanical (plough) discharge and steep cone self discharge are in operation. Of late only flat bottom ones, with capacity of automated recycling are in progressive use. Basically, these machines have a cylindrical perforated basket duly ribbed for strength fitted to a shaft driven by AC or DC motor fitted at the top. The basket is provided with supporting liners and fine screens of crystals in the basket and easy passage of molasses to the draining channel in the motor casing. Masecuite for purging is charged from top and sugar is discharged through the bottom of the basket which during running operation is closed by a stop valve. The basket is provided with arrangement of water or steam wash applications.



VIEW OF A BATCH TYPE CENTRIFUGAL

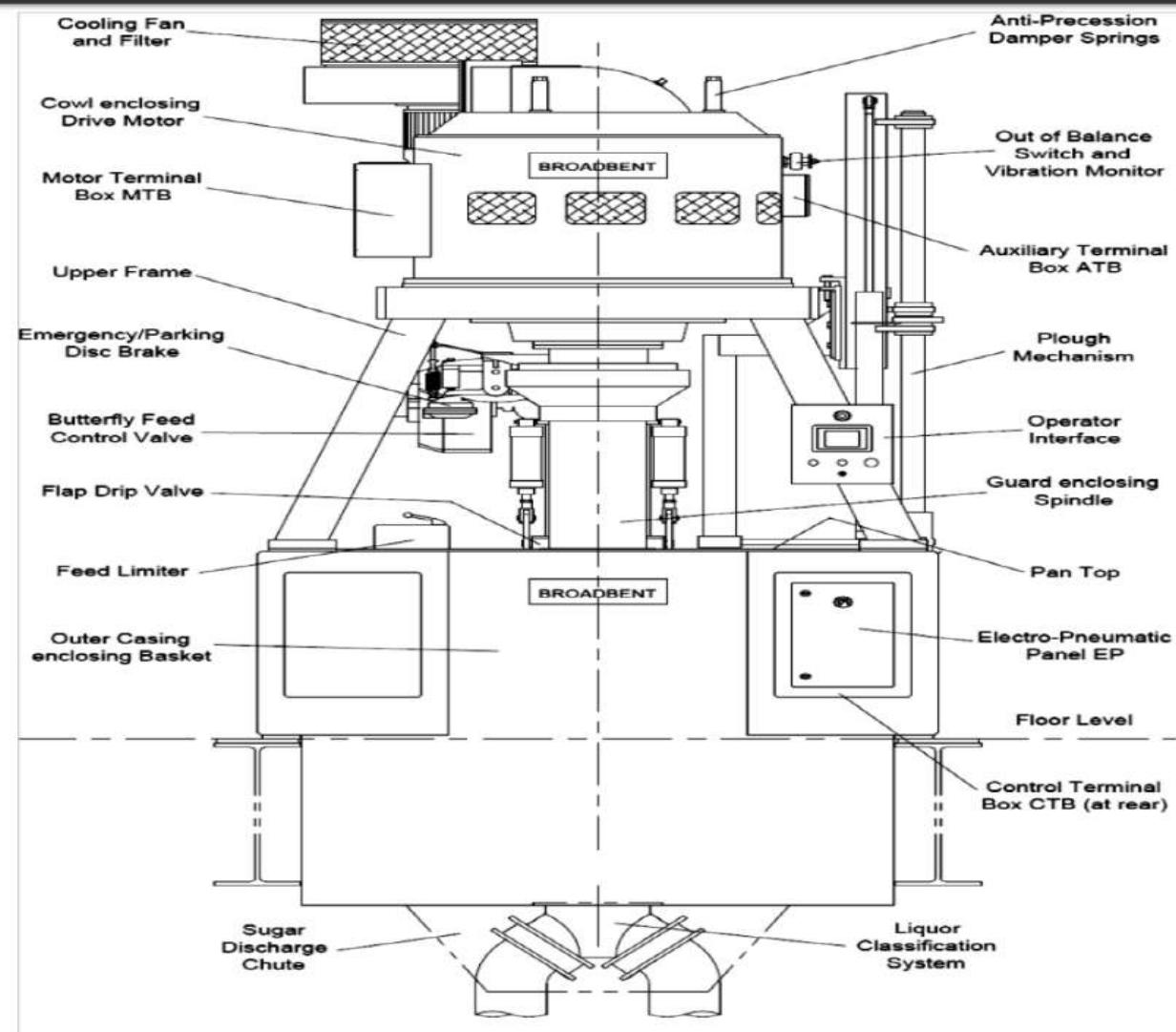



Continuous Centrifugals

As its name implies this type of centrifugal machines are used to cure continuously low grade massecuite of high viscosity at constant speed of 1500-2000 rpm. The centrifugal is fed continuously by the massecuite and the cured sugar is discharged continuously at high speed. Thus, it avoids wastage of time and power in frequent stopping & starting of the machine, charging and discharging.

Mainly two types of Continuous Centrifugal Machines are being used in sugar industry.

1. Horizontal Continuous Centrifugal Machine
2. Vertical Continuous Centrifugal Machine

An Overview of Continuous Centrifugal

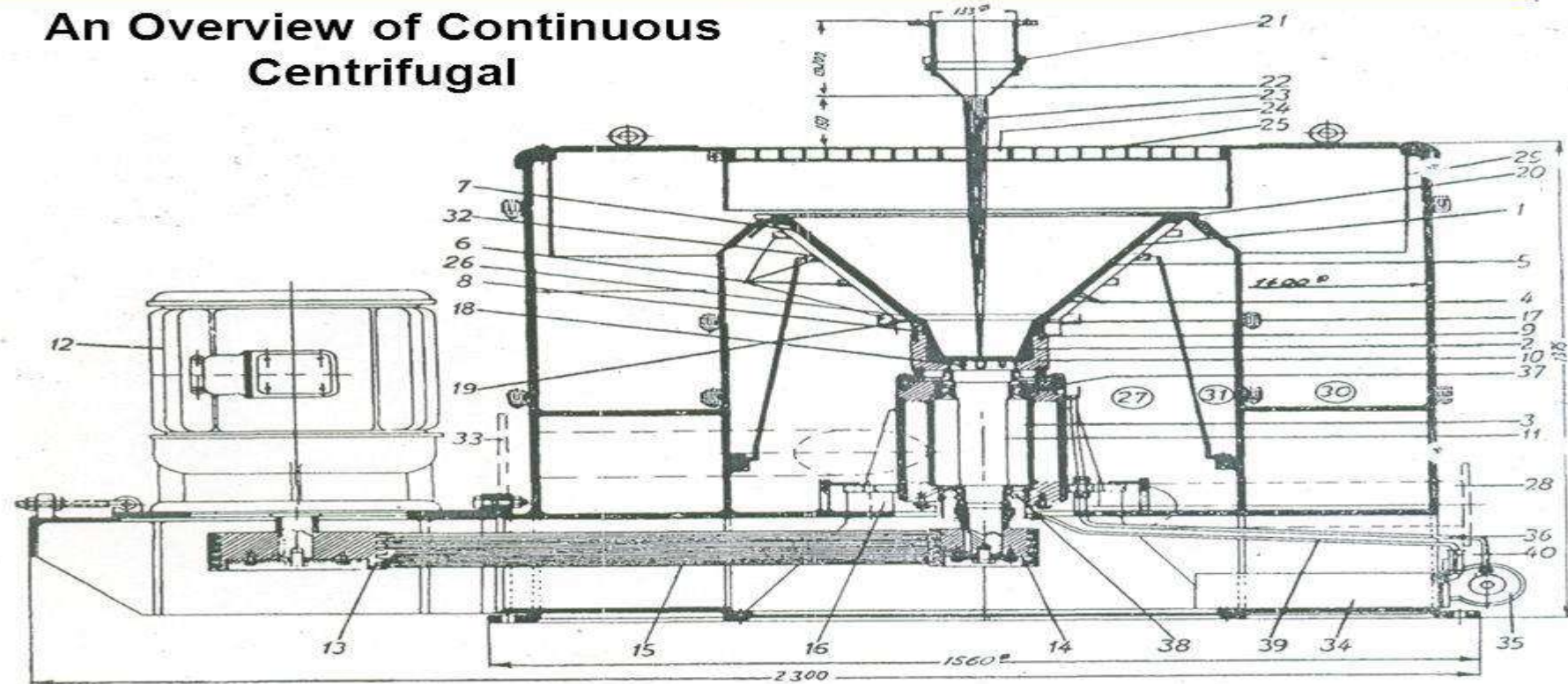

1. Conically shaped screen
2. Accelerating device
3. Driving system
4. Grooved drum of screen basket
5. Ring system supported by 16 triangular ledges
6. Four holding rings
7. Slit screen
8. Connecting screws
9. Set pins
10. Conical top
11. Shaft
12. Motor
13. V-belt pulley

15. V-belt
16. Rubber blocks
17. Conical ring
18. Counter sunk screws
19. Rubber cord
20. Clamp ring
21. Ring of heating pipe
22. Inlets of various nozzle sizes
23. Mousseite flow
24. Centre hole
25. Grid
26. Beginning of screen
27. Greens discharge space
28. Tangentially placed discharge pipe for greens

29. Rubber wall
30. Solids space
31. Wash discharge space
32. Conical separating baffle
33. Tangentially placed discharge pipe for wash
34. Oil container
35. Electric oil pump
36. Oil pipe
37. Upper cylinder roller bearings
38. Lower roller bearings
39. Return oil pipe
40. Sight glass



FACTORS AFFECTING CENTRIFUGAL PERFORMANCE

1. Uniformity of grain size
 2. Viscosity of mother liquor
- **Un-even grains having a packing affect on the layer of sugar which renders the passage of molasses difficult. False grains or conglomerates formation in pans or even in crystallizers leads to un-even crystal size formation. Since, molasses has to travel through the voids in the crystals, mixed crop of crystals reduces effective area of passage and thus proper separation of molasses.**
 - **In curing low grade massecuites, B & C particularly, viscosity plays a crucial role in bringing down the rate of separation and passage of molasses through voids. It can be reduced either by heating to saturation temperature or diluting.**



Batch vs Continuous Centrifugals

The batch type machines have some operational disadvantages/limitations which are overcome in continuous machines:

1. Continuous Centrifugals work on the thin layer principle as the massecuite centrifuged from the centre point and separate molasses and sugar by the action of developed centrifugal force at high rpm. First component of the centrifugal force along the basket wall expels the sugar out of the basket. Centrifugal force exerting on the material depends upon the gravity factor which is directly proportional to the diameter of the basket and square of the speed.



2. In batch machines there is low efficiency in use of energy due to acceleration and braking in each cycle.
3. Complex nature of motors in batch machines which has to have different speeds.
4. Loss of time in charging and discharging in case of batch machines.

However, the continuous machines are not used for curing high grade massecuite due to following reasons:

1. Erosion of crystals as the massecuite layer moves up.
2. Crystal breakage due to impact of crystals against the wall of monitor casing when they are thrown out of the basket.



SUGAR HANDLING

The final Sugar discharged from the A or Refined centrifugal machines has to be dried, cooled and conveyed for grading and packing. The drying of sugar is mostly accomplished in the centrifugals with application of steam or superheated water which also performs the function of washing the sugar crystals free of the adhering film of molasses. After discharge from the centrifugals during its passage to packing the moisture of sugar needs to be reduced to 0.05 per cent & temperature down to 40°C. Sugar with higher moisture content and temperature is prone to deterioration, caking and development of colour.

Dried and cooled plantation white sugar is graded by sieving through vibratory screen multi-deck graders to separate the grain size grades designated as L, M, S & SS in accordance with the India Sugar Standards. For refined sugars, these grades are L_R, M_R, S_R and SS_R.



DRYING & COOLING OF SUGAR

After discharge from the centrifugals, the bagging sugar during its travel for grading and bagging, can be conditioned using:

1. ROTARY DRYERS
2. GRASS HOPPER CONVEYORS
3. FLUIDIZED BED DRYERS & COOLERS

The sugar has to be dried and cooled as discussed in the earlier slides so as to have a longer shelf life.



ROTARY DRYERS

It consists of rotary drum provided with flights on selected angle to give very effective movement for sugar without disturbing the crystal shine. It is equipped with wet scrubbing system to control sugar dust and fully automatic system for regulating flow of hot air.

- **Construction**

The complete system is in mild, carbon steel or stainless steel fabrication from plates. The air discharge is taken from the bottom of the drier head box. The discharge end of the drum is also fitted with a 316 S.S. circumferential 10 mm mesh screen 500 mm in length to separate the crystals from any lumps.

- **Lifting Flights**

There are helical baffles fitted along with the drum length. There are adequate baffles each of suitable height and covering 120 deg. of the drum circumference fitted to lead the Sugar in forward motion.



VIEW OF A ROTARY DRYER





View of Scooping





GRASS HOPPER CONVEYOR

Grass hopper conveyor is made up of a trapezoidal- shaped trough of light sheet (3 mm thick) mild steel, reinforced by angle iron. The portions where connecting rods fixed are strengthened by 8/10 mm thick M.S. plates. The hopper is not welded on longitudinal sections. It is riveted by rivets. Hoppers have one or two connecting rods with ball / roller bearing. The eccentricity of shaft (where connecting rod is connected) is 16 to 20 mm. The hopper trough is supported on wooden springs which are mounted at about 60° with the horizontal on the base angles.

The driving unit mounted on M.S. fabricated base frame, consists of a steel crank shaft with two fly wheels, mounted on roller bearings with housing steel / wooden connecting rod is connected with the housing of steel crank shaft. Steel crank shaft is coupled with V- belt pulley and motor. Connecting rod conveys a shaking movement to the trough, the stroke being 16 to 20 mm, rotating at 300 rpm. These hoppers are provided in hot and cold air blowing arrangement



View of a Hopper





FLUIDIZED BED DRYERS & COOLERS

Fluid bed dryer are found throughout all industries, from heavy mining to food, fine chemicals and Pharmaceuticals and sugar industry. It's use in sugar industry has picked during the last two decades as besides providing effective conditioning of sugar it provides solution to space constraints. It is stationary equipment, provided with FD and ID pans, with various capacities from 15T/hr to 50T/hr along with dust catching system. They provide an effective method of drying relatively free flowing particles with a reasonably narrow particle size distribution.

In general, fluid bed dryers operate on a through-the-bed flow pattern with the hot air passing through the product perpendicular to the direction of travel. The dry product is discharged from the same section.

Fluidized Bed Dryer & Cooler



Flow Sheet Fluid Bed Dryer/Cooler

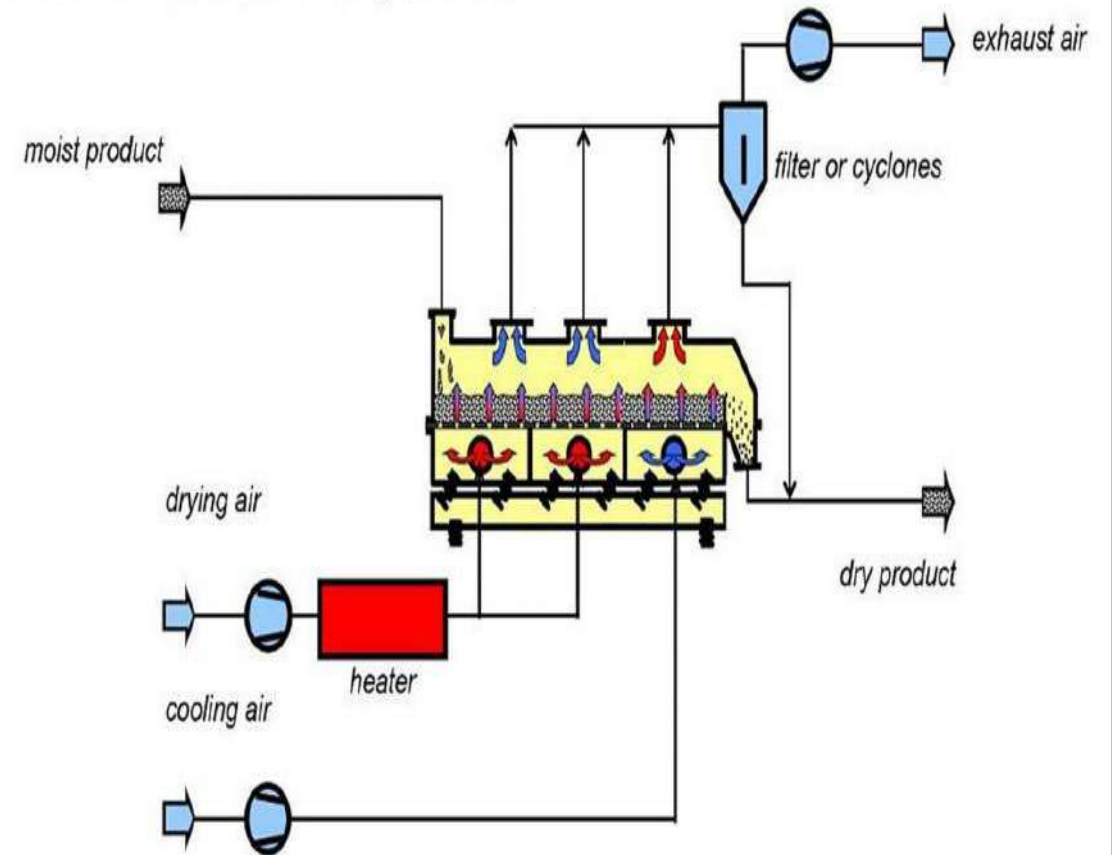

Combinations of drum dryer and fluidized-bed cooler

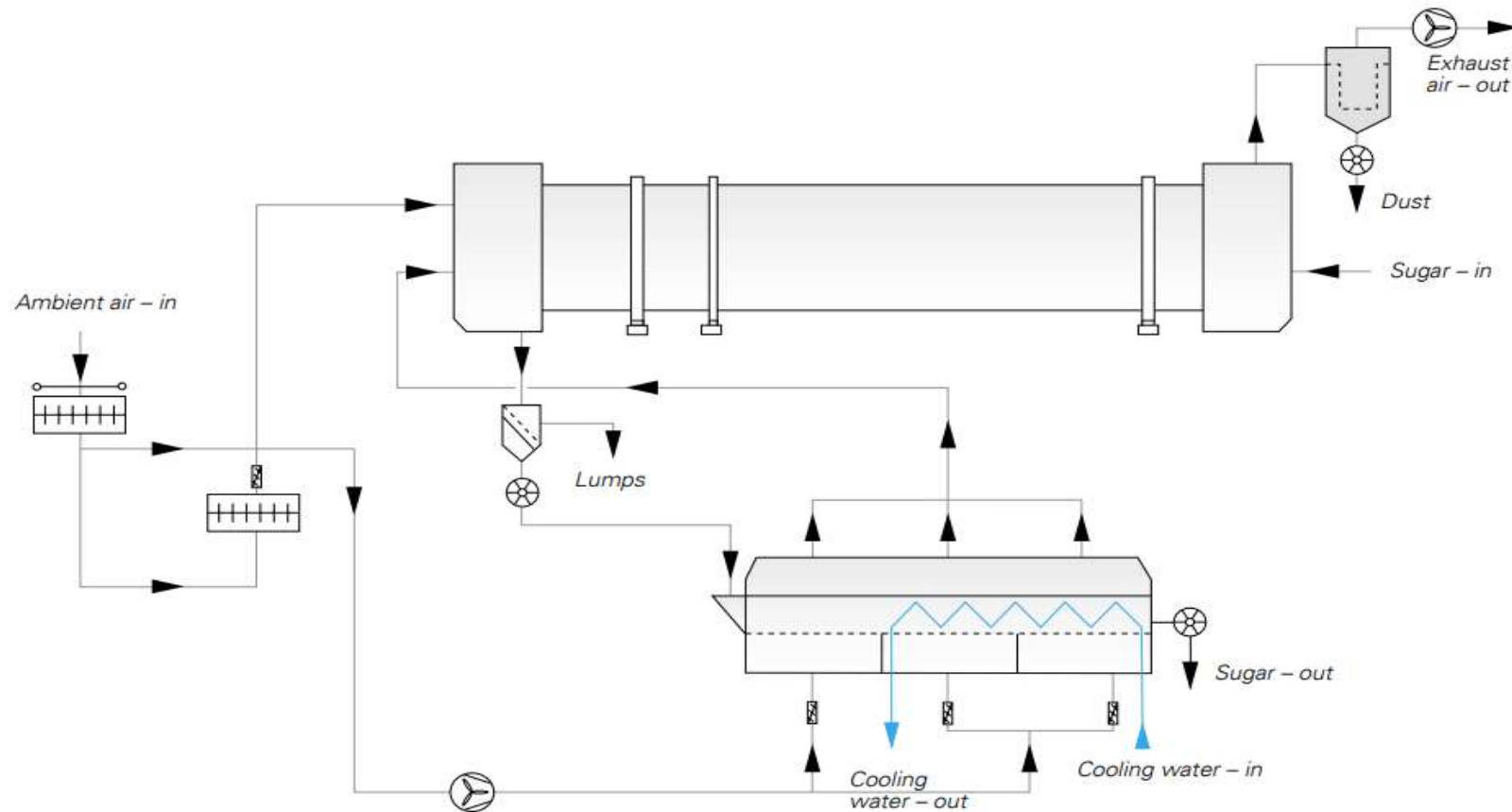



ADVANTAGES OF FLUIDIZED BED DRYERS & COOLERS

- High rate of heat and mass transfer is achieved.
- Moisture reduction from 1.5% to 0.02-0.03%.
- Sugar temperature should be close to wet bulb temperature of air. This allows gentle drying without caramelization of sugar.
- Excellent solution for the factories undertaking capacity expansion and having space constraints.
- The gentle drying and cooling process brings with it an excellent product quality, especially with regards to brightness of the product.
- The enlarged cross-section above the fluid bed reduces dust discharge.
- Stationary type / No hopper movement reduces crystal breakage.
- Lower maintenance due to absence of moving parts.



SUGAR ELEVATORS

It is essential to transport the dry sugar from hopper/fluidized bed dryer cum cooler/ Rotary Dryer to top of sugar grader which is accomplished by a bucket elevator. The elevator may be either straight vertical or inclined. Encased in a closed steel case the elevator consists of two strands of endless chain and bucket is bolted between two chains, the distance between the buckets being around 30-35cms. The elevator moves at speed of about 20-30 m/min. and lifts the sugar to a height of 10 to 15m. & delivers it into the chute leading to top of sugar grader.



GRADER

The function of grader is to classify sugar into different size grains & to separate small lumps as well as dust from the sugar to be marked. The entire equipment is of sturdy construction consisting of 3 to 4 or more screens enclosed in a steel frame. The screens bolted in frames have separate chute at the discharge ends. The grader is a vibrating mechanism with screens inclined at about 35° to the horizontal.

The vibration generated in the screens allow separation of oversize & undersize grains at each screen, oversize grains flowing over screen are collected at the chute. With three or four screen it is possible to separate three grades of sugar conforming to different size grains.



VIEW OF A GRADER & GRADING+ WEIGHING SYSTEM

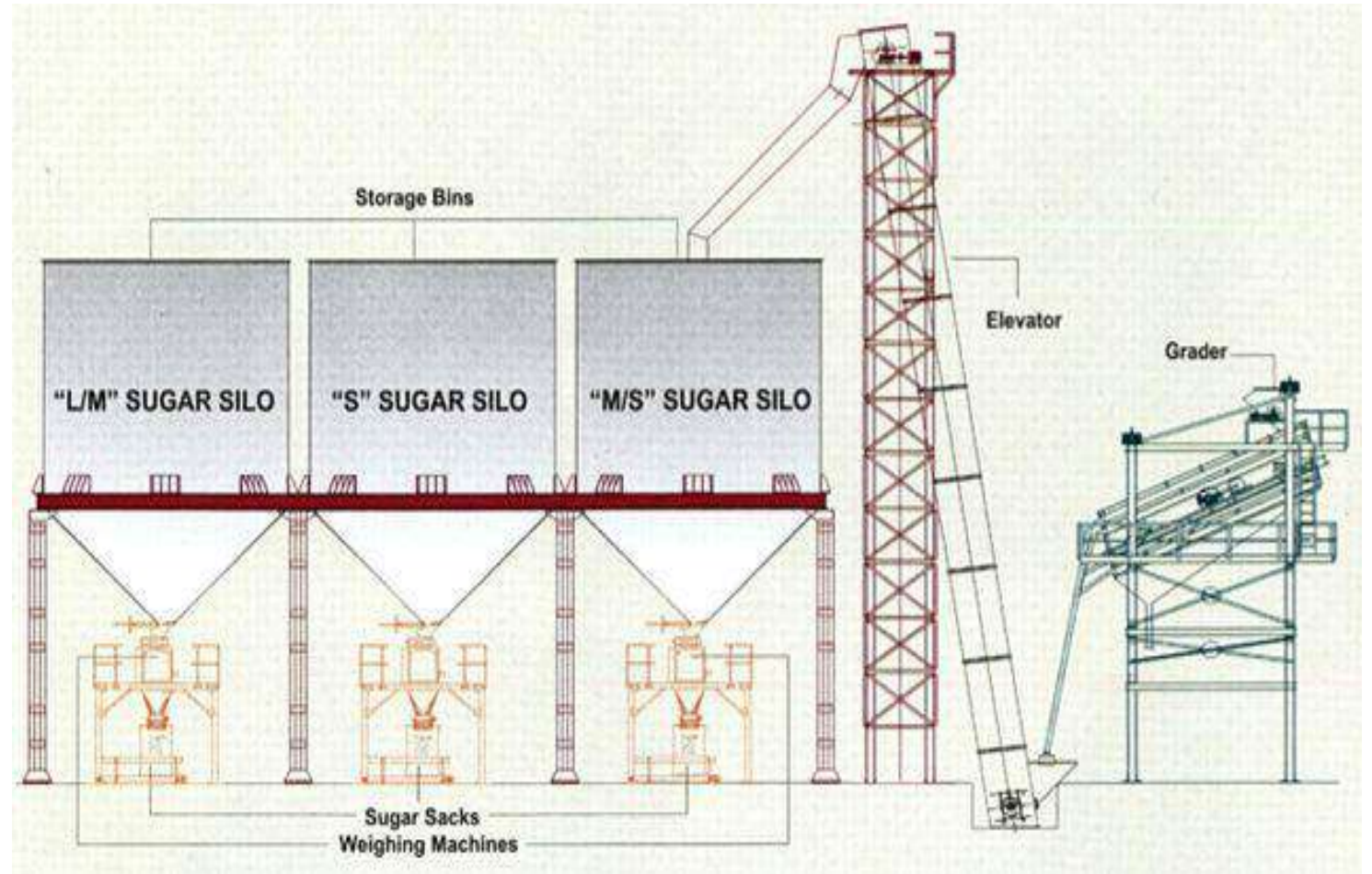



MAGNETIC IRON SEPARATORS

These are provided in grader outlet chute. This consists of a aluminum fabricated sugar bag holder hinge type with tilting type brackets lock fitted with magnet plate to separate M.S. particles from sugar.



PLANTATION WHITE SUGAR SPECIFICATION

S. NO.	CHARACTERISTIC	REQUIREMENT	METHOD OF TEST , REF TO CLAUSE OF 15279
1	Loss on drying percent by mass, Max	0.10	4
2	Polarization, Min	99.5 Z	5
3	Reducing sugars, percents by mass, Max	0.10	7
4	Colour in ICUMSA units Max	150	8
5	Conductivity ash. Percent by mass. Max	0.10	9
6	Sulphur Di-oxide. Mg/kg, Max	50.0	13
7	Lead , mg/kg/.Max	5.0	15



GRAIN SIZE REQUIRED FOR SUGAR CRYSTALS

GRADE DESIGNATION	PASSING THROUGH		RETAINED ON	
	IS SIEVES	TYLER	IS SIEVES	TYLER
L-31	2.36mm	8	1.70mm	10
L-30				
M-31	1.70mm	10	1.18mm	14
M-30				
S-31	1.18mm	14	0.60mm	28
S-30				
SS-31	0.60mm	28	0.212mm	65